

**German Financial Cooperation with the Republic of
Indonesia**

**Procurement of Construction Works for the Completion
of UNHAS Hospital Buildings B, C, D**

**Employer:
Ministry of Education and Culture of the Republic of
Indonesia**

Question & Answers

for

ITB Nr.: 505203 BMZ209918111-Construction Works-1

Questions from bidder dated March 5th, 2020

1. To participate in this tender, what data should be provided? Please explain the registration process.

Answer:

The terminology of registration process may different from your point of view and KfW guidelines point of view. Regarding the procedure to participate in this tender, please refer to the **instruction for bidders in the tender documents page 5 section 1**.

2. We have attached Letter of Interest here. Should we send the hard copy? If yes, when the deadline is? Can we submit it at pre bid meeting? Please advise.

Answer:

According the the KfW guidelines for procurement of goods, works, and associated services in financial cooperation with partner countrie;, we don't need a letter of interest to participate in the tender. Instead, you should follow the **instruction for bidders in the tender documents page 5 section 1**.

3. Please inform the contact person of pre-bid meeting. Also, what documents/data that we have to bring for the meeting?

Answer:

The PIC for pre bid meeting is Ms. Sumarni (08124206347). The meeting will start at 10.00 am 11 March 2020 at Unhas Teaching Hospital PIU Office. You don't need to register to participate in this meeting but you may contact her to inform your willingness to come. Basically, we don't need any document during this meeting.

Questions from bidder dated March 13th, 2020

A. Administration:

1. Pada ITB 33.1, Kurs yang digunakan dalam penawaran adalah Kurs USD dari Bank Indonesia tertanggal 7 hari sebelum batas pemasukan penawaran. Konfirmasi apakah yang dimaksud adalah tanggal 14 April 2020? Mohon penjelasannya.

At ITB 33.1, the exchange rate used in the bid is the USD exchange rate from Bank Indonesia dated 7 days before the bid entry limit. What confirmation does this mean is April 14, 2020? Explanation please

Answer:

It clearly stated in ITB 15.1 point (a) that **the unit rates and the prices shall be quoted by the Bidder in the Schedules, entirely US Dollars (US\$)**.

In case bidder wants to use local currency, there is an option in ITB 15.1 (b) as follow:

The rates of exchange to be used by the Bidder in arriving at the local currency equivalent and the percentage(s) mentioned in (a) above shall be specified by the Bidder in the Appendix to Bid - Table C, and shall apply for all payments under the Contract so that no exchange risk will be borne by the successful Bidder.

Please carefully read entirely ITB 15.1 and make cross reference with ITB 33.1.

2. Sesuai ITB 18.1, masa berlaku penawaran selama 120 hari. Pada ITB 19.3 dipersyaratkan masa berlaku Jaminan Penawaran adalah 42 hari melebihi masa berlaku penawaran. Mohon konfirmasinya, apakah masa berlaku jaminan menjadi 162 hari terhitung mulai dari jadwal pembukaan penawaran?

In accordance with ITB 18.1, the validity period of the offer is 120 days. In ITB 19.3 the validity period of the Bid Security is 42 days after the validity period of the offer. Please confirm, is the guarantee validity period of 162 days from the opening schedule of the offer?

Answer:

Yes

3. Untuk jaminan penawaran apakah bisa menggunakan asuransi/ konsorsium?

To guarantee the offer can we use insurance / consortium?

Answer:

According to ITB 19.3, the Bid Security is in the form of an unconditional guarantee issued by **a bank or financial institution** (such as an insurance, bonding or surety company) from a reputable source from an eligible country as specified in Section V, Eligibility Criteria. If the unconditional guarantee is issued by a financial institution located outside the Employer's Country, the issuing financial institution shall have a correspondent financial institution located in the Employer's Country to make it enforceable.

Consortium is not allowed.

4. Apakah jaminan penawaran disetor terpisah sebelum batas pemasukan penawaran, atau jaminan penawaran tergabung dalam dokumen yang disetorkan sebelum batas pemasukan penawaran?

Is the bid guarantee paid separately before the bid entry limit, or guarantee the bid is incorporated in the documents deposited before the bid entry limit?

Answer:

A valid Bid Security from the bank must be presented with the Bid on the bid submission date as to ITB 22.1

5. Mohon dapat diberikan daftar personil dan alat yang dibutuhkan?

Can you please provide the list of personnel and equipment needed?

Answer:

On page 47, clause 3.6 you find the required key personnel. All other staff and workers shall be suggested by the bidder. There is no specific requirement for special equipment (see page 48, clause 3.7).

6. Di dalam penawaran ini, selain BOQ apakah analisa harga satuan, daftar upah, perlu dilampirkan? Kalau ada dokumen lain yang perlu dilampirkan tolong disebutkan.

In this offer, besides BOQ, does the unit price analysis, wage list, need to be attached? If there are other documents that need to be attached, please mention.

Answer:

Unit price analysis and wage list are not asked in the tender. Anyhow, additional information such as unit price analysis, wage list, material price list can help to analyse your bid. You may attach documents as much as you think is needed to understand your bid.

7. Untuk lampiran dalam penawaran ini, seperti kontrak-kontrak pengalaman, legalitas perusahaan, dll yang menggunakan Bahasa Indonesia, apakah harus ditranslate kedalam Bahasa Inggris? Mohon penjelasannya.

For attachments in this offer, such as experience contracts, company legality, etc. who use Indonesian, should it be translated into English? Beg the explanation

Answer:

Basically yes. In case original documents of experience contracts and company legality are in Bahasa Indonesia, only then we will accept it.

8. Pada section III, Qualification and Evaluation Criteria, poin 4.2 (a) Dipersyaratkan memiliki pengalaman Kemampuan menerapkan volume konstruksi 10 juta USD dalam 1 tahun.
Pada poin 4.2 (b) dipersyaratkan beberapa key activities, apakah kelima key activities ini mengacu kepada persyaratan pengalaman pada poin 4.2 (a) diatas, atau bisa menggunakan beberapa pengalaman lain untuk memenuhi key activities yang dipersyaratkan?

In section III, Qualification and Evaluation Criteria, point 4.2 (a) Required to have experience Ability to apply construction volume of 10 million USD in 1 year. At point 4.2 (b) several key activities are required, do these five key

activities refer to the experience requirements in point 4.2 (a) above, or can you use some other experience to fulfil the required key activities?

Answer:

Yes, the requirement in 4.2 (b) refers to either 4.1 (a) or also any other contracts (For the above or any other contracts completed...)

9. Apabila ber-KSO, apakah masing-masing anggota KSO harus memiliki pengalaman kelima key activities yang dipersyaratkan? Atau bisa saling melengkapi antar anggota KSO? Mohon penjelasannya

If having an KSO, does each KSO member have to have the experience of the five key activities required? Or can complement each other among KSO members? Explanation please

Answer:

In case of a JV (Joint Venture) this applies to all parties combines as defined in the table on page number 40-41.

10. Untuk persyaratan pengalaman pekerjaan Healthcare building, level general, or teaching (university hospital), minimum project volume 20.000 sqm, apakah perhitungan luas ini dihitung per lantai? Mohon penjelasannya.

For the Healthcare building work experience requirements, general level, or teaching (university hospital), a minimum project volume of 20,000 sqm, is this area calculated per floor? Explanation please.

Answer:

It is clearly defined: "a multi-floor building for such a healthcare project not less than 20,000 sqm gross area". Gross area means all floors combined.

11. Untuk pembayaran apakah menggunakan system Fixed Price (Is) atau unit price?

For payments using the Fixed Price (Is) or unit price system?

Answer:

Please refer to the clause 14 "Contract and Payment" on page 225 and also refer to the Particular Conditions of Contract starting on page 260

12. Sistem pembayaran apakah menggunakan termin atau MC?

Does the payment system use terms or MC?

Answer:

Please refer to particular condition of contract sub clause 14.4, on page number 1198.

13. Apakah ada uang muka? Apabila ada, berapa uang muka yang diberikan oleh owner?

Are there any down payment? If there is, what advance is given by the owner?

Answer:

Please refer to particular condition of contract sub clause 14.4, on page number 1198.

14. Untuk personil, apakah ada SKA yang dipersyaratkan?

For personnel, is there a SKA required?

Answer:

Yes, it may be attached.

15. SBU apa yang dipersyaratkan pada pelelangan paket ini?

What SBU is required at the auction of this package?

Answer:

Yes, it may be attached.

Technical:

1. Apakah ada tersedia tempat pembuangan/disposal? Mohon penjelasannya.

Is there waste disposal area available? Explanation please.

Answer:

There is no waste disposal area provided. Contractor should take all waste of construction to Tempat Pembuangan Akhir (TPA).

2. Berapa lama masa pemeliharaan?

How long is the maintenance period?

Answer:

The Defects Notification Period is 720 days after acceptance. Refer to clause 1.1.3.7 on page 260. Please also refer to the contract template, clause 11 “defects liability” starting on page 216

3. Harga satuan material dan upah apakah menggunakan kurs USD?

Does the unit price of material and wages use the USD exchange rate?

Answer:

Please refer to the answer of question 1 (Administration).

Questions from bidder dated March 20th, 2020

1. Mohon diberikan informasi urutan kekuatan dokumen antara dokumen Bill of Quantity, Gambar dan RKS?

Please give me information the strengten sequence of document between Bill of Quantity, Drawing and Spesification Document?

Answer:

We refer to Section IV Qualification and Bidding Forms, page 83 “Schedules”, here “Preamble No. 1 to 10. Also, you find further explanation in Section VIII General Conditions, Chapter 12 “Measurement and Evaluation”, 12.2. and 12.3.

2. Apa sifat kontrak ini, Lumpsum Fixed Price atau Unit Price? Atau kombinasi keduanya?

What is the nature of this contract, Lumpsum Fixed Price or Unit Price? Or combination of both?

Answer:

Please refer to Clauses 14.xx Contract Price and Payment on page 225 and also refer to the Particular Conditions of Contract starting on Page 260

3. Apakah ada uang muka? Bila ada, berapa persen?

Is there any down payment? What percentage?

Answer:

The advance payment is 10% from contract amount excl. taxes. Please refer to Section IX, Particular Conditions of Contract Subclause 14.4

4. Apa sistem pembayaran yang digunakan pada kontrak ini, berdasarkan progres tiap bulan atau berdasarkan prosentase progress yang ditentukan?

What is the payment system used in this contract, based on monthly progress or based on specified percentage of progress?

Answer:

Based on specified percentage. Please refer to Section IX, Particular Conditions of Contract Subclause 14.4

5. Apakah ada batas waktu pelaksanaan pelaksanaan proyek?

Is there any restrictions time for the construction of this project?

Answer:

Time for completion is 390 days. Please refer to Section IX, Particular Conditions of Contract Subclause 1.1.3.3

6. Dapatkah saya meminta gambar dengan arsiran yang menunjukkan area mana yang perlu perbaikan (termasuk pembongkaran dan instalasi) dan area mana yang perlu diselesaikan (tanpa pembongkaran)? Karena kondisi ini mempengaruhi harga untuk kedua kondisi yang berbeda dalam item pekerjaan dalam bill of quantity.

Can I request for drawing with shading that show which area is need to be repaired (include disassembly and installation) and which area is need to be resolved (without disassembly)? Because this condition affect the price for both different condition in the works item in bill of quantity.

Answer:

The areas for repair works are described and illustrated in the tender documentation.

7. Spesifikasi material tidak menginformasikan merek yang ditentukan. Apakah kami diizinkan untuk menawarkan merek yang kami tahu sesuai dengan spesifikasi yang diminta? Atau owner akan menentukan merek saat proyek berjalan?

Material specifications do not inform the specified brand. Are we permitted to offer brands that we know which comply with the specifications requested? Or the owner will determine the brand when the project is running?

Answer:

The specification criteria in the tender documentation must be fulfilled with the offered materials / components.

8. Bisakah saya mendapatkan garis besar spesifikasi dalam format excel?

Can I get the specification outline in the excel format?

Answer:

Specifications are available only in PDF.

9. Bisakah Anda memberi saya gambar detail untuk jenis pekerjaan pintu dan jendela?

Can you give me the detail drawing for the type of door and window work?

Answer:

The doors and windows are described sufficiently in the tender documentation with schedules, specification and drawings.

10. Dapatkah kami menerima informasi mengenai HPS dalam Paket lelang ini

Can we get the information about Owner's Estimate of Construction Cost for this bidding?

Answer:

No, the KfW Procurement rules for International Competitive Bidding do not allow that the Owner's Price Estimates to be published in the tender.

The BoQ on page 16 is a contingency given as fixed value of 1,5 Mio USD. The contingency is added to each bid price. A contingency is used for unforeseen works and is not connected in any way with a price estimate.

11. Dalam Section II Bagian C. Preparation of Qualification Documents and Bids, ITB 19.1 "The Amount and Currency of the bid security shall be: 2.5% of the bid price in USD." Tolong dapat disebutkan nilai Bid Security dalam nominal (bukan dalam persentase)? atau tolong dipertimbangkan untuk mengubah syarat menjadi ITB 19.1 "The Amount and Currency of the bid security shall be: 2.5% of the bid price in USD." Karena Proses pengurusan Jaminan Penawaran membutuhkan waktu, sedangkan harga penawaran kami mengalami perubahan hingga batas akhir pemasukan penawaran.

In Section II Part C. Preparation of Qualification Documents and Bids, ITB 19.1 "The Amount and Currency of the bid security shall be: 2.5% of the bid price in USD." Can you mention the value (in USD not in percentage) of bid security? Or Please consider to change the clause of ITB 19.1 to be "The Amount and Currency of the bid security shall be: 2.5% - 3 % of the bid price in USD." Because the process of bid security takes time, while the bid price always changes until the deadline of bid Submission.

Answer:

The Bid Security of 2,5% of the bid price in USD cannot be changed.

12. Mohon diinfokan mengenai Tujuan Jaminan Penawaran dan Surat Penawaran (Dalam Nama dan Alamat Lengkapnya)

Please give us the information about the purpose of the security bid, Letter of Bids

Answer:

Please refer to Section IX Particular Condition, Subclause 1.1.2.2.&1.3.

13. Apakah benar data dibawah ini:

- a. Nama Proyek: Hospital UNHAS Hospital Development Project, Makassar, BMZ 2099 18 111
- b. Alamat Panitia: PIU KfW-UNHAS Office, Jl. Perintis Kemerdekaan km. 10, Cancer Center Building 1st floor, PIU room, 90245 Makassar, South Sulawesi
- c. Nama Panitia/Pemberi Kerja: The Ministry of Research, Technology and Higher Education of the Republic of Indonesia

Data ini diperlukan untuk pengurusan Jaminan Penawaran, Surat Penawaran dan dokumen penawaran lainnya.

Is the data below correct?

- a. The Name of the Project: Hospital UNHAS Hospital Development Project, Makassar, BMZ 2099 18 111
- b. committee address: PIU KfW-UNHAS Office, Jl. Perintis Kemerdekaan km. 10, Cancer Center Building 1st floor, PIU room, 90245 Makassar, South Sulawesi
- c. Full Name of Employer: The Ministry of Research, Technology and Higher Education of the Republic of Indonesia

This data is required for the administration of bid guarantees, letter of Bid, etc.

Answer:

Point (a) : correct

Point (b) : UNHAS Hospital Development Project, Makassar, BMZ 2099 18 111

Point (c) : The name of the Employer changed to The Ministry of Education and Culture of the Republic of Indonesia

14. Untuk lampiran Qualification Forms seperti legalitas perusahaan (Akte perusahaan. Ijin usaha dan sertifikat perusahaan) serta Kontrak Pengalaman Perusahaan apakah harus ditranslate dalam bahasa inggris? Mohon Penjelasan. Mengingat batas akhir Pemasukan Dokumen Penawaran Tanggal 20 April 2020 dan saat ini Negara kita sedang terkena Wabah COVID-19 sehingga mempersulit dalam pengurusan data-data tersebut. Mohon Pertimbangannya agar dokumen2 tersebut diperbolehkan dalam bahasa indonesia.

For attachments to Qualification Forms such as company legality (company certificate. Business license and company certificate) as well as company experience contracts, should they be translated in English? Please explain. Considering the deadline for Submitting Bid Documents on April 20, 2020 and currently our country is being affected by the COVID-19, making it difficult to administer the data. Please consider that these documents are allowed in BAHASA

Answer:

Such attachments must not be translated. They can be submitted in BAHASA

15. Ketika Pemasukan Penawaran apakah diperlukan untuk membawa dokumen asli legalitas perusahaan (yang dilampirkan pada Dokumen Kualifikasi) Seperti, akte perusahaan, Sertifikat, Ijin Usaha?

When Bid submission, should we bring an original documents of company (Attachment of Qualification Documents) like company deed, certificates, business permit?

Answer:

Originals of this type of documents need not to be submitted. Copies will be sufficient

16. Jika perusahaan kami tidak JO dalam Pelelangan ini, maka Form ELI - 1.2 (a) Apakah perlu diisi? Mohon penjelasan. Kalau tetap perlu diisi, maka diisi informasi apa?

If our company does not JO in this Bidding, then ELI Form - 1.2 (a) Does it need to be filled out? Please explain? If it still needs to be filled in, what information is filled in?

Answer:

If no JV is being formed that ELI 1.2 (a) is not needed

17. Mohon dapat diberikan Dokumen yang dapat diedit (Softcopy) dari Section IV. Qualification and Bidding Forms, untuk mempersingkat waktu?
Please give us the editable (Softcopy) of Section IV. Qualification and Bidding forms, to shorten the time?

Answer:

You will get this Section separately as WORD file

18. Mohon dijelaskan sistem penilaian panitia dalam pelelangan ini (Sistem Nilai, Sistem Gugur atau lainnya)?

Please Explain about the Criteria of Evaluation Bidding Documents. (The Evaluation is Values System or etc).

Answer:

Please refer to Section III, Qualification and Evaluation Criteria for Qualificaiton and Evaluation of bids. Especially refer to the table showing the criteria of evaluation at Clause 3.1. of the ITB, Section III

19. Tolong jelaskan tentang jenis kontrak (lump sum atau harga satuan atau gabungan dari lump sum dan harga satuan).
Please explain about the type of contract (Lumpsum or unit price or combined of Lumpsum and Unitprice).

Answer:

Refer to your question 2 for the answer (duplicate question).

20. Siapa yang bertanggung jawab jika ada kegagalan dalam kualitas struktur

Who's take the responsibility if there is a failure in the quality of the structure?

Answer:

This question is not relevant to the bidding process. Any (not expected) failure of the structure or other existing elements must be examined case by case. E.g. if the existing structure might be compromised by the Contractor who stored too much weight in some areas, it might be the fault of the Contractor violating the restrictions of loads on the floors etc. There is no general answer to your question.

21. Pada Section IV. Qualification and Bidding Forms Hal. 61 Form FIN - 3.1 Financial situation and Performance. Laporan Keuangan Tahun berapa saja yang dipersyaratkan (Apakah Laporan Keuangan Tahun 2014, 2015, 2016, 2017, 2018)?

In Part IV. Qualification and Bidding Form. Page 61 FIN Form - 3.1 Financial Situation and Performance. Financial Statements. Which year is required (What are the 2014, 2015, 2016, 2017, 2018 Financial Statements)?

Answer:

Refer to tables 3 in Section Iii. For example for 3.2 „Financial Capabilities“ the last 5 years shall be covered

22. Mata uang yang digunakan pada form CON - 2, Form FIN - 3.1, Form FIN - 3.2, Form FIN - 3.3, Form FIN - 3.4, Form EXP - 4.1, Form EXP 4.2 (a), and Form EXP 4.3 (b) apakah USD/EUR? Mohon Penjelasan.

The Currency that used on the form CON - 2, Form FIN - 3.1, Form FIN -3.2, Form FIN - 3.3, Form FIN - 3.4, Form EXP - 4.1, Form EXP 4.2 (a), and Form EXP 4.2 (b) are USD/EUR? Please Explain.

Answer:

Please use US-Dollars (USD)

23. Pada Section III. Qualification and Evaluation Criteria di tabel Part 4.2 (b) Construction Experience in key activities, Hal. 41. "No. 3) The Bidder has to provide proof that he has enough manpower available to work in parallel in several floors, roofs and façade with the target to finish the requested scope of work within the requested time frame of 390 days" Untuk Memenuhi syarat tersebut, data apa saja yang perlu kami lampirkan?

In Section III. Qualification and Evaluation Criteria on tabel Part 4.2 (b) Construction Experience in key activities, Page 41. "No. 3) The Bidder has to provide proof that he has enough **manpower** available to work in parallel in several floors, roofs and façade with the target to finish the requested scope of work within the requested time frame of 390 days" to meet these requirements, what kind of data do we need to attach?

Answer:

Any documents, like contract data, acceptance protocols which give proof that you finished such work within the time frame of 390 days

24. Mohon penjelasan cara pengisian Formulir: a. Form CER - 5.1 Certification b. Form ESHS EXP-5.2 Experience in Projects with significant ESHS Impact c. Form ENV-5.3 Environmental Management Capacity d. Form OHSAS-5.4 Occupational Health and Safety Capacity e. Form LOC-5.5 Socially Responsible Works Implementation f. Form COC-5.6 Ethical Business Principles g. Form PR-5.7 List of Available ESHS and Construction Personnel

Please explain how to fill the forms: a. Form CER - 5.1 Certification b. Form ESHS EXP-5.2 Experience in Projects with significant ESHS Impact c. Form ENV-5.3 Environmental Management Capacity d. Form OHSAS-5.4 Occupational Health and Safety Capacity e. Form LOC-5.5 Socially Responsible Works Implementation f. Form COC-5.6 Ethical Business Principles g. Form PR-5.7 List of Available ESHS and Construction Personnel

Answer:

For form CER 5.1 you attach a certificate which is either ISO 9001 or an equivalent.

As for forms EXP-5.2 you refer to any projects you implemented with a significant ESHS impact. If you do not implemented a project with significant ESHS level, list whatever project you implemented with any ESHS level. This will be sufficient to qualify, as the Unhas project is being rated ESHS Level 2, which is not a significant ESHS impact.

To fully understand the requirements asked for in tables 5 ESHS Experience and Capacity please refer to Section VI, Clause 2 Social and Environmental Responsibility and Section VII the Chapter ESHS.

25. Dalam Formulir PR - 5.7 Daftar ESHS dan Tenaga Konstruksi yang Tersedia. Personel ESHS yang harus diisi dalam formulir adalah personel ESHS khusus untuk proyek ini atau personel ESHS yang tersedia di perusahaan. Mohon Penjelasan.

In Form PR - 5.7 List Of Available ESHS and Construction Personnel Page 58. ESHS personnel that should be filled in the form are ESHS personnel specific to this project or ESHS personnel that available at the company. Please Explain.

Answer:

Please refer to the Section VII Works Requirements c) Personnel Requirements. Each bidder shall nominate an ESHS Manager which is responsible for implementation of ESHS management plans for construction works. As this project is rated ESHS Level 2 the requirements are not defined in detail. This may be an assigned ESHS Manager for this project or the manager is available already in the bidders organisation

26. Apakah bisa diusulkan uang muka sebesar 15%?

Can a 15% down payment be submitted?

Answer:

No, this is not possible.

27. Apakah bisa Masa pemeliharaan menjadi 180 hari kalender sesuai Perpres?

Can the maintenance period be 180 calendar days in accordance with Presidential Regulation?

Answer:

No, because this tender is in compliance with the KfW regulations for the procurement of goods, services and works.

28. Apakah jam kerja dapat dilaksanakan 24 Jam dalam 7 hari?

Can working hours be done 24 hours in 7 days?

Answer:

Yes, 7/24 is always possible.

29. Mohon penjelasan mengenai Jenis kontrak yang akan Digunakan untuk Pekerjaan ini **Lump sum atau Unit price?**

Please explain the type of contract that will be used for this work of lumpsum or Unit price?

Answer:

Please follow the BoQ where this is consistent accordingly.

30. Apakah Material On site bisa di progresskan?

Can the Material on the Site be developed?

Answer:

Material on-site cannot be considered as progress. All works items will be counted as progress after installation and commissioning.

Please follow the BoQ where this is also considered accordingly.

31. Apakah ada item Pekerjaan NSC (*Nominated Sub Contractor*) dan DC (*Direct Contractor*)? Mohon dijelaskan Scope tanggung jawab Kontraktor?

Are there work items for NSC (Designated Sub-Contractor) and DC (Direct Contractor)? Please explain the scope of contractor's responsibilities?

Answer:

The contractor either as single entity or JV is fully responsible for the fulfilment of contract.

32. Bagaimana Urutan keberlakuan dokumen?

What is the order of validity of documents?

Answer:

There is no order of documents, except that documents for Qualification have to be separated from the technical and financial bid

33. Bagaimana kompensasi keterlambatan pembayaran dari pemberi tugas ke kontraktor?

How is compensation for late payment from the assignor to the contractor?

Answer:

Please refer to clause 14.8. of the General Conditions of Contract in Section VIII

34. Apakah berlaku Serah terima pekerjaan Parsial?

Does partial job delivery apply?

Answer:

PHO (Partial Hand Over) = the first handover takes place after the end of the work contract period (maintenance period is excluded). After the maintenance period, FHO takes place.

35. Apakah berlaku pekerjaan tambah kurang?

Is there less work?

Answer:

Please carefully read Section VIII, Clause 13 Variations and Adjustments. Variations of work and quantities are possible under the subclauses under 13.xx

36. Bagaimana mekanisme pengembalian uang muka?

What is the mechanism for returning down payment?

Answer:

Advance payment (down payment) is explained in the response for Questions 3. The advance payment is a loan from the employer which will be returned in several portions as can be seen in the payment scheme in Section IX, Particular Conditions of Contract Subclause 14.4

Question from the Bidder dated March 23rd, 2020

1. Can we build a temporary living quarter inside or around project area?

Answer:

Yes you can.

2. Where is the disposal area in this project?

Answer:

There is no waste disposal area provided. Contractor should take all waste of construction to Tempat Pembuangan Akhir (TPA).

3. Should the former demolition be given to the owner? or the contractor's responsibility?

Answer:

Demolition, wherever necessary, is part of scope of the Contractor

4. Can we use an existing lift for transport the materials?

Answer:

No, the existing Patient lifts will definitely be damaged by transporting building materials, this is not acceptable.

5. There is an existing water and electricity in site? can we use that for this project?

Answer:

Water and electricity is available on site. However it will not be free of charge.

6. Because an existing tile should be have the same with the new one, can we have the spesification adn the brand from old spesification?

Answer:

No, the new material shall be similar to the existing, please use the provided specifications and descriptions

7. Can we use inside the building as a temporary office?

Answer:

This is possible whenever it is not affecting the construction activities and schedules

8. There is door and window unit type D1-069-1 (1st Floor) in Bill of Quantity, but we can't find the location of D1-069-1 in Door Schedule, should we follow the BoQ or the Drawing?

Answer:

Please follow the BoQ.

Question from the Bidder dated March 27th, 2020

1. Please Explain about the Criteria of Evaluation Bidding Documents. (The Evaluation is Values System or etc).

Mohon Penjelasan mengenai Sistem Evaluasi pada Paket Pelelangan ini.

Answer:

The evaluation criteria are all explained in the tender document.

2. Section III. Qualification and Evaluation Criteria Page. 40 on table Part 4.2 (b) Construction Experience in key Activities There was 5 Criteria of experience.

Questions:

a. Should we complete all criteria of experience? If there was a criteria that we dont attached in Bid

Documents, is it make a Failed or just affect scoring of experience? Please Explain

b. Criteria no. "5) not less than 2 renovation / retrofitting multi-floors healthcare or educational projects with not less than 20,000 sqm gross area within the last 10 years as sub-, prime or general contractor"

Question: to complete this criteria should we attached a renovation / retrofitting experienced in office or another building project (not in healthcare or educational projects) Please Explain.

Bagian III. Kriteria Kualifikasi dan Evaluasi Halaman 40 pada tabel Bagian 4.2 (b) Pengalaman Konstruksi dalam Kegiatan-Kegiatan Utama Ada 5 Kriteria pengalaman.

Pertanyaan:

a. Haruskah kita melengkapi semua kriteria pengalaman? Jika ada kriteria yang tidak kami lampirkan pada

Dokumen Penawaran, apakah itu mengugurkan atau hanya memengaruhi sistem penilaian pengalaman?

b. Persyaratan no. "5) not less than 2 renovation / retrofitting multi-floors healthcare or educational projects with not less than 20,000 sqm gross area within the last 10 years as sub-, prime or general contractor"

Pertanyaan : Untuk memenuhi persyaratan ini, apakah kita dapat melampirkan pengalaman renovation/retrofitting pada bangunan kantor atau Proyek

Answer:

You have to complete ALL CRITERIA describing your experience and competence. The tables are well described in the tender.

If you have difficulties fully understand the English text, have it translated on your own expense.

3. Section IX. Particular Condition, Part A- Contract Data, Explained that Defects Notification Period are 720 days. Is it permissible for the Defects Notification period to be in 6 months.

Di Section IX. Particular Conditions tertera masa pemeliharaan 720 Hari kalender. Apakah diperbolehkan untuk masa pemeliharaan menjadi 6 bulan

Answer:

No, it has to remain 720 days.

4. How long will it take to process The Payment Certificate after submitted?

Berapa lama jangka waktu BA Progress lapangan/sertifikat terbit setelah pengajuan progress?

Answer:

This is not a question relevant for your bid and cannot be answered.

5. How many days time to Payment since The Payment Certificate was issued?

Berapa lama jangka waktu pembayaran sejak sertifikat terbit?

Answer:

This is not a question relevant for your bid and cannot be answered.

6. Please Change the Payment System to a Monthly Progress Payment?

Dimohon sistem pembayaran dapat diubah menjadi monthly progress payment

Answer:

No, the payment system remains as mentioned in the Tender.

7. Please Give us the Information regarding Schedule Auctions. Specifically for the appointment schedule of winners (please give us the information about the date), how many days time from submitting bids? Does it take up to 1 year?

Mohon Informasi mengenai Jadwal Pelelangan. Khususnya untuk jadwal penunjukan pemenang berapa lama dari waktu pemasukan penawaran? Apakah memakan waktu sampai 1 tahun?

Answer:

The length of the tender process through various stages according to the KFW guidelines used.

8. For The Percentage of Retention please changed to 5% of the Accepted Contract Value

Dimohon untuk retensi dapat diubah menjadi 5% dari Nilai kontrak.

Answer:

The percentage of retention has to remain as mentioned in the tender

9. Whose responsibility is it regarding the application for Licensing for electric power, telephone, PDAM? Please Explain

Permohonan Perijinan daya listrik, telephone, PDAM termasuk lingkup siapa? Mohon Penjelasan

Answer:

Unhas

10. Please explain the document hierarchy, if there are differences between BOQ, Drawing & Technical Specifications which documents are referred to.

Mohon dijelaskan hierarki dokumen, apabila ada perberdaan antar BOQ, Gambar & Spesifikasi Teknis dokumen mana yang menjadi acuan.

Answer:

We refer to Section IV Qualification and Bidding Forms, page 83 "Schedules", here "Preamble No. 1 to 10. Also, you find further explanation in Section VIII General Conditions, Chapter 12 "Measurement and Evaluation", 12.2. and 12.3.

11. The product lift in the Documents is listed mitsubitshi ExThailand, Japan. Which one is used? Thailand or Japan. Please explain

roduct lift didalam RKS tercantum mitsubitshi ExThailand, Jepang. Mana yang digunakan? Thailand atau Jepang. Mohon dijelaskan

Answer:

The brand offered are adjusted to the dimensions of the existing space

12. Can We apply for Variation Orders work? Please explain

Apakah dapat mengajukan pekerjaan Tambah Kurang? Mohon Penjelasan

Answer:

Please refer to Section VIII. General Conditions (GC), Section 13

13. In Drawings Documents Explained that Block Diagram electrical system accepted by MDB to LVMDP (existing). However, in BOQ Documents Explained that there was item works of Trafo, LVMDP, Panel TM and Generator Set. Which documents are referred to. Drawing or BOQ. Please Explain

Dalam Gambar block diagram electrical system disebutkan MDB ke LVMDP Existing. Tetapi dalam BQ tercantum Trafo, LVMDP, Panel TM dan Genset yang digunakan yang mana? Mohon dijelaskan

Answer:

Please refer to the relevant BoQ sections and follow the items described here.

14. Please Give us The drawings of Single Line Diagram Main Electrical. (LVMDP, Trafo, P-TM, Genset)

Mohon diberikan Gambar Single Line Diagram Elektrikal Utama. (LVMDP, Trafo, P-TM, Genset)

Answer:

No additional drawings will be provided. Please refer to the relevant BoQ sections and follow the items described here. Please refer also to the marking “fixed price item”, “lump sum” and description of works in particular.

15. Related to Fire Alarm works, Sound System works, Telephone works & MATV Data works explained that the equipment is Existing. Are These Works Doesn't need to be offered? Please Explain

Terkait Fire Alarm, Sound System, Telephone & Data MATV. Dalam Pekerjaan Tersebut equipment Existing. Apakah tidak perlu ditawarkan? Mohon dijelaskan

Answer:

Please refer to the descriptions of works. There is an existing part of the hospital with executed works and there is a part where only the core & shell is existing and the described works have to be executed in accordance with the BoQ.

16. Are the Main Medical Gas Work Equipment not included in this Package Projects? Because in Documents of BoQ and Drawings didn't Existed. Please Explain

Apakah Main Equipment Pekerjaan Gas Medis tidak termasuk dalam Pekerjaan Sekarang? Dikarenakan Bq dan Gambar tidak tercantum. Mohon dijelaskan.

Answer:

Medical Gas in a working condition is already installed in the Wards. Therefore there is no need to include this in the BoQ and drawings

17. Because of Covid - 19 Virus was occurred in this country, please the PIU to be considered to postpone the process of bidding until fine condition

Dikarenakan sedang mewabahnya virus COVID-19, dan pemasukan penawaran adalah penyerahan langsung ke PIU, mohon batas akhir waktu pemasukan penawaran dapat diundur sampai dengan kondisi kondusif.

Answer: For the time being, the due date is in accordance to ITB 22.1. If there is any changes we will announce it soon

18. Related to previous question, Please changed the Process of Bidding Documents Submission to Online Submission. If permitted, Please give us the information about the procedurs of Online Sumbmission. And Does the Bid Security still have to be submitted directly to PIU or can be followed until Fine conditions. Please explain

Mohon penyerahan dokumen penawaran dapat dilakukan secara online. Apabila diperbolehkan mohon penjelasan mengenai prosedurnya. Apakah jaminan penawaran tetap harus diserahkan langsung ke PIU atau dapat menyusul sampai dengan kondisi kondusif. Mohon Penjelasan

Answer:

Submitting via online is under discussion between PIU and KFW. For the time being submission follows ITB 22.1. If there is any changes we will announce it soon.

Question from the Bidder dated April 6th, 2020

A. ADMINISTRASI

1. Mencermati Virus Corona yang saat ini semakin mewabah di Indonesia, dan dengan diberlakukanya sistem kerja 100% Work From Home (WFH) untuk semua perusahaan di Indonesia termasuk subkont dan supplier material, hal ini semakin mempersulit kami dalam penyusunan dokumen. Dengan pertimbangan diatas mohon pemasukan dokumen dapat diundur menjadi tanggal 08 Mei 2020.

Concerning corona crisis in Indonesia and 100% Work from Home system for all companies, including subcontractor and material supplier, we find it difficult to develop our bidding documents. Regarding that, please consider pushing back the date of bid submission to 08 May 2020.

Answer:

For the time being, the due date is in accordance to ITB 22.1. If there is any changes we will announce it soon

2. Pemasukan dokumen penawaran mohon untuk dapat dilakukan secara online (upload) mengingat semakin sulitnya transportasi umum saat ini dan untuk menghindari resiko penyebaran virus corona saat melakukan perjalanan.

Please allow online bid submission (upload) as it is hard to find public transportation and to mitigate the corona virus spreading.

Answer:

Submitting via online is under discussion between PIU and KFW. For the time being submission follows ITB 22.1. If there is any changes we will announce it soon.

3. IMB menjadi tanggung jawab siapa?

Who is responsible for building permit (IMB) application?

Answer:

The building already has an IMB.

4. Untuk IMB apakah saat ini sudah proses, jika sudah sampai sejauh mana?

Regarding building permit (IMB), is it under process of applying? If yes, how far is the progress?

Answer:

The building already has an IMB.

5. Izin-izin untuk penyambungan daya PLN, PDAM, Telephone dan Pemadam Kebakaran apakah termasuk dalam paket pekerjaan MEP?

Do permits of power, water, phone, and fire protection include in the MEP?

Answer:

Yes, it is included in the MEP.

6. Denda keterlambaran berapa % per hari, dari harga kontrak atau dari sisa Kontrak dan maksimal berapa %

How much late charge per day (%)? Does the percentage is calculated from contract price or from the remaining value of the contract? How much the max of late charge (%)?

Answer:

This is 0,2% of the final Contract Price per day. The maximum amount is 10% of the final Contract Price. Please also refer to Subclauses 8.7 of the Contract specimen.

7. Mohon diberikan Ceklist dokumen apa saja yang harus kami sampaikan untuk keseragaman semua peserta Tender

Please provide a checklist of what documents we must submit for uniformity of all tender participants

Answer:

There is no checklist of what documents must be submitted. Please refer to the document tender.

8. Bolehkan kami melakukan survey lapangan ulang untuk melihat lokasi lebih detail ? jika iya kami harus menghubungi siapa ?

Can we resurvey the site for detail observation? If yes, who's to contact to?

Answer:

Yes you can. Please sent a letter to PIU.

9. Tanggal berapa pengumuman pemenang dan Rencana Kontrak ?

When will be the announcement of contract winner and contract plan?

Answer:

The announcement of the contract winner will be after completion of all the evaluations and the formal "No Objection" of KfW to the evaluation reports. The time frame cannot be given.

10. Untuk jaminan penawaran apakah harus menggunakan USD? atukah bisa dalam Rupiah ?

Should we use USD or IDR for bid security?

Answer:

Please use USD

11. Format Jaminan penawan apakah boleh menggunakan standar dari Bank? atau harus sesuai dengan format yang diberikan ?
Can we use bank template for bid security format, or must we refer to the provided format?

Answer:

You may also use a bank template, as long as all required information as in the provided format is available

12. Apakah diperlukan surat dukungan material dari Pabrik / Distributor?

Do you need supporting letter from manufacture/distributor?

Answer:

Supporting letters from manufacturers/distributors are not required

13. "Letter Of Qualification" dan "Letter of Bid" didalam form ditujukan kepada siapa?

Who is the addressee of "Letter of Qualification" and "Letter of Bid"?

Answer:

The Ministry of Education and Culture of the Republic of Indonesia

14. Format surat Kerjasama Operasi (KSO) / Joint Venture apakah formatnya bebas?

Can we use free format for JV letter?

Answer:

You may use free format for a JV letter. It must clearly state the form of JV, the lead firm and must carry all signatures of the JV partners.

B. TEKNIS

1. Apakah Barak pekerja boleh di lokasi pekerjaan ?

Do you allow to build worker housing on the construction site?

Answer:

Yes, you do.

2. Apakah outline spesifikasi teknis yang kami sampaikan harus menyebutkan merk/produk yang ditawarkan ?

Does technical specification outline that we submit should mention the brand of product proposed?

Answer:

The bidder shall fulfil the specifications as per technical documentation and demonstrate this. Bidders can submit supporting documents with e.g. brand names and supporting technical documentation

3. Dinding Ruang OT menggunakan material apa ? karena di dalam BQ belum kami temukan material tersebut, apakah termasuk tahap saat ini.

What material to use in OT wall? We did not find it in the BoQ. Does the work include in the scope of work?

Answer:

Material is Gypsum partition wall with HPL panel 12mm thick, with aluminium frame; 40mm thick mineral wool and all necessary fitting accessories under the Section 08.1 Ref. no. 08.1.2. Letter H.

4. Kapan estimasi pelaksanaan pekerjaan harus dimulai ? hal ini untuk keperluan penyusunan jadwal pelaksanaan

When the work is estimated to start? We need this to develop our work plan.

Answer:

As soon as possible after contract signature.

5. Finishing Epoxy pada BQ Section 09 : Floor Finishes menggunakan ketebalan berapa micron ?

Regarding Finishing Epoxy at BQ Section 09: how many microns on Floor Finishing thickness?

Answer:

Standard 3mm (1/8 inch) or 3000 microns

Question from the Bidder dated April 6th, 2020

1. Based on Keputusan Badan Nasional Penanggulangan Bencana No. 13.A / 2020, Dated 29th February 2020 About "Perpanjangan Status Keadaan Tertentu terhadap Wabah Virus COVID - 19" which is Valid for 91 days start from 29th February 2020 until 29th May 2020 (Letter Atteched) And Presidential Decree No. 11/ 2020 dated 31th March 2020 which stipulates that COVID - 19 as a disease that impact to public health emergencies. As well as Republic of Indonesia Government Regulation No. 21 / 2020 regarding Large-Scale Social Distantion in the context of accelerating the handling of Corona Virus Disease 2019 (COVID-19). Please Consider to postponed the deadline for submission of bids until the Status is revoked (status against COVID-19 is well).

Berdasarkan Keputusan Badan Nasional Penanggulangan Bencana Nomor 13.A Tahun 2020, Tanggal 29 Februari 2020 Mengenai Perpanjangan Status Keadaan Tertentu terhadap Wabah Virus COVID - 19 yang berlaku selama 91 Hari terhitung sejak tanggal 29 Februari 2020 sampai dengan tanggal 29 Mei 2020 (Surat Terlampir) dan Keputusan Presiden Nomor 11 Tahun 2020 tanggal 31 Maret 2020 yang menetapkan bawa COVID - 19 sebagai penyakit yang menimbulkan kedaruratan Kesehatan Masyarakat. Serta Peraturan Pemerintah RI Nomor 21 Tahun 2020 mengenai Pembatasan Sosial Berskala Besar dalam rangka percepatan penanganan Corona Virus Disease 2019 (COVID - 19). Mohon Batas akhir waktu pemasukan penawaran dapat diundur sampai dengan Status tersebut dicabut (keadaan terhadap Status Wabah Virus COVID - 19 Membaik).

Answer:

For the time being, the due date is in accordance to ITB 22.1. If there is any changes we will announce it soon.

2. In the Form BID Security (Section IV), there is information about the name of the work package, is it right that the name of Project is Hospital UNHAS Hospital Development Project, Makassar, BMZ 2099 18 111 (without mentioning the ICB number and ICB title?). Please explain

Pada Format Fomulir BID Security (Section IV), terdapat informasi mengenai nama paket pekerjaan, apakah benar nama paket pekerjaan yaitu Hospital UNHAS Hospital Development Project, Makassar, BMZ 2099 18 111 (tanpa menyebutkan Nomor ICB dan title ICB?). Mohon Penjelasan

Answer:

To have it fully complete, please add the ITB Number, which is 505203 BMZ209918111-Construction Works-1

3. Is Following data correct? (This information to fill the Forms) : a. ICB No. And Title : 505203 BMZ209918111-Construction Works or UNHAS building B,C,D b. ICB No. : BMZ209918111-Construction Works

Apakah benar data berikut (untuk pengisian Forms) : a. ICB No. And Title : 505203 BMZ209918111-Construction Works or UNHAS building B,C,D b. ICB No. : BMZ209918111-Construction Works

Answer:

The ITB Number is 505203 BMZ209918111-Construction Works-1

4. In the Forms Bid Security (Section IV) there is an Invitation Number for Bids (IFB) data. Could you inform the IFB numbe? Because the IFB that we have seen on the website or in the newspapers there is no IFB number listed.

Pada Forms Bid Security terdapat data Nomor Invitation for Bids (IFB). Mohon dapat diinfokan Nomor IFB yang dimaksud ? Karena IFB yang kami lihat dalam website maupun Koran tidak ada nomor IFB yang tertera.

Answer:

There is no IFB Number. Please use ITB Number 505203 BMZ209918111-Construction Works-1

5. Are there provisions for the file in the digital copy submitted, the file is in all pdf format or what?

Apakah ada ketentuan untuk bentuk file dalam digital copy yang diserahkan, File nya dalam bentuk pdf semua atau bagaimana?

Answer:

Refer to ITB 20.1: in addition to the originals of the Qualification Document and the Bid, the number of copies is two (2) and one (1) digital copy on flash drive. All the files in the digital copy on flash drive should be in PDF, except for the BoQ please give us also in excel file.

6. In File BOQ There Is section 16 but Section 15 doesn't exist. Is there a lack of File BoQ or does section 15 not exist? Please Explain

Pada BOQ terdapat section 16 tetapi section 15 tidak ada. Apakah ada boq yg kurang atau memang section 15 tidak ada

Answer:

There is no section 15 in the BoQ.

7. Are there specialized subcontractors required? if any, please explain what attachments that we Should attached on Bid Document

Apakah dipersyaratkan Specialized Subkontraktor? jika ada, tolong jelaskan lampiran apa yang harus kami lampirkan pada dokumen penawaran

Answer:

The need, type and skills of subcontractors is your choice. If you feel the need to include any subcontracting, feel free to do so

Question from the Bidder dated April 8th, 2020

1. Mohon Penjelasan mengenai Merk dari Pompa Hydrant?

Please explain about merk of Fire Pump?

Answer:

For the fire pump, please follow the BoQ, drawings and specifications as per tender documentation.

2. Mohon diberikan informasi mengenai jenis dan merek Alumunium Composite Panel (ACP) yang digunakan dalam fasade bangunan existing. Karena kontraktor harus mencocokkan merk dan warnanya agar seragam.

Please give information about the type and the brand of the Alumunium Composite Panel (ACP) which is used in the existing building fasade. Because the contractor must match the brand and its color to make it uniform.

Answer:

Please follow the detailed BoQ, drawings and specifications. Offered ACP can be different brand from the existing.

3. Bolehkah kontraktor menyarankan untuk mengganti semua ACP pada fasade bangunan existing dengan material ACP baru? Karena jika kita tidak mengganti ACP yang lama dengan yang baru, maka akan ada perbedaan tampilan walaupun jenis dan warna material yang digunakan sama.

May the contractor suggests to replace all the ACP in the existing building fasade with new ACP materials? Because if we don't replace the existing ACP with the new one, there will be any different appereances even the type and color are same.

Answer:

Please follow the detailed BoQ, drawings and specifications. Offered ACP can be different brand from the existing.

4. Mohon diberikan informasi mengenai spesifikasi material untuk pekerjaan atap metal yang dipasang miring di lantai atap bangunan. Juga jenis, merek dan warnanya.

Please give information about material specifications for metal cladding which is install tilted in the roof floor of the building. Also the type, brand and its color.

Answer:

Please follow the detailed BoQ, drawings and specifications. Offered ACP can be different brand.

5. Pada Dokumen dipersyaratkan melampirkan Softcopy Dokumen Penawaran. Mohon dijelaskan dalam format apakah dokumen yang di submit pada Softcopy. Apakah dalam Softcopy dokumen penawaran dalam format .pdf sedangkan Dokumen BOQ dalam format excel? Mohon Penjelasan.

On documents are required to attach Softcopy of Bid Documents. Please explain in what format of document that we should submitted on Softcopy. Is the softcopy of the bidding document in (.pdf) format while the BOQ document is in excel format? Please explain.

Answer:

All the files in the digital copy on flash drive should be in PDF, except for the BoQ please give us also in excel file. Softcopies for Qualification documents and Bids shall be on different media. Please carefully read ITB Clause 21 about Sealing and Marking of Qualification Documents and Bids

6. Mohon untuk dapat dipertimbangan terkait penundaan atau perpanjangan batas akhir pemasukan dokumen penawaran terkait update status Pembatasan Sosial Berskala Besar (PSBB) terhadap Penawangan Wabah COVID - 19.

Please take into consideration the delay or extension of the deadline for bid submission regarding the status update of the Large-Scale Social Restrictions (PSBB) for Handling the Pandemic of COVID-19

Answer:

For the time being, the due date is in accordance to ITB 22.1. If there is any changes we will announce it soon

Question from the Bidder dated April 13th, 2020

1. Tolong jelaskan spesifikasi Door Protection tipe A, B dan C dalam file UNHAS_R.6.9_Renov_Doors Sched- B_AU_2010_01_24

Please explain the specification of Door Protection type A, B and C in the file UNHAS_R.6.9_Renov_Doors Sched-B_AU_2010_01_24

Answer:

Wall Plates, protection - .040" (1.02mm) and .060" (1.52mm) thick Acrovyn or .060" (1.52mm) polycarbonate sheet.

Door edge protectors are available in two styles, a "U" shape and an "L" shape. Specify Acrovyn sheet in .040" (1.02mm) or .060" (1.52mm) thickness or 16 gauge stainless steel. Please refer to the specification in the tender documentation.

2. Mohon diberikan gambar detail dinding DWG No.A.8.9 karena yang kami terima hanya sampai no gambar DWG No.A.8.8

Please give the detail drawing file DWG number A.8.9 because there are only drawing number A. 8.1 until A. 8.8 that we received.

Answer:

Please refer A.11.35 Drawings under A.11 Detail Drawings for the File.

3. Land Improvement pekerjaan no 14.3.4 Sum pits and pumps dan pada gambar A.15 belum ada gambar detail sumpits hanya terdapat kapasitas saja. Mohon dijelaskan ukuran panjang, lebar dan tinggi sumpit yg direncanakan dan mohon dapat diberikan gambar detail sumpitnya.

Land Improvement work no. 14.3.4 Sumpits and pumps and also in file folder A.15, there is no detailed picture of the sumpits, but there is only capacity.

Please explain the length, width and height of the sumpits that were planned and please give its detailed drawing.

Answer:

Please refer to Fixed price item - Section VII, Works requirements, a-1) Scope of Works, page 106, Fixed Price Item 4. The bidder has to make assumptions for his lump sum price.

4. Land Improvement pekerjaan drainase L. Basement terdapat pekerjaan Pipa Air Hujan menuju kolam penampungan, berapakah ukuran pipa yang digunakan dan mohon diberikan gambar detailnya

Land Improvement drainage work L. Basement there is a work of Rainwater Pipes to the reservoir, what is the size of the pipe used and please provide detailed pictures

Answer:

Please refer to Fixed price item - Section VII, Works requirements, a-1) Scope of Works, page 106, Fixed Price Item 4. The bidder has to make assumptions for his lump sum price.

5. Untuk Besarnya Nilai Jaminan Penawaran disyaratkan 2,5% dari Nilai Penawaran. Apakah diperbolehkan nilainya lebih dari 2,5% dari Nilai Penawaran?

On Documents, for the amount of Bid Security is 2.5% of the Bid Value. Is it permissible if the amount of Bid Security more than 2.5% of the Bid Value?

Answer:

The bid security may be submitted above 2,5% of the bid value.

6. System RO kapasitasnya berapa? dikarenakan dalam BQ & Gambar System Maupun denah tidak tercantum, Mohon dijelaskan.

How many is capacity of the RO system? because in the BQ & Drawing System or floor plan is not listed, please explain.

Answer:

Please see attached the R.O technical specification.

7. Mohon diberikan Spesifikasi Material Pekerjaan Gasmedis, Fire Hydrant

Please give Material Specification of Gasmedis work, Fire Hydrant Work.

Answer:

Please refer to the folder “MEP specifications” and “Arch Civil Specifications”, here: R12, S05, S12, S34 etc. Please refer also to the materials as in the BoQ 11.3.

8. Mohon diberikan Gambar System Panel PP-PXR 2.1 & PP-PXR 2.2

Please give us Drawing of Panel System PP-PXR 2.1 & PP-PXR 2.2.

Answer:

The Panel System for already indicated in the Electrical drawing. Herewith we attached again the drawing No. E-303 for your reference

9. Mohon diberikan Gambar LVMDP dikarenakan Dokumen yang lama tidak ada dan DiBQ tercantum Pekerjaan Modifikasi LVMDP

Please give us Drawing of LVMDP because in Document does not exist and In BQ is listed as an LVMDP Modification Work. Please Explain

Answer:

The LVMDP works in only provided with the allocation as the provisional sum. The appointed Contractor shall check to the existing location and installation, and shall conduct the necessary modifications according to the applied Electrical System.

10. Penilaian Construction Experience yang terdapat Pada Section III. Qualification and Evaluation Criteria Points 4. Construction Experience, a Minimum of 80 out of 100 points has to be reached Subpoints 4.2 (b) Construction Experience in Key Activities. Dijelaskan bahwa :

For the above or any other contracts completed and under implementation as prime contractor, joint venture member, management contractor or subcontractor on or after the first day of the calendar year during the period stipulated in 4.2(a) above, a minimum construction experience in the following key activities successfully completed :

1) healthcare building, level general or teaching (University Hospital), minimum project volume 20,000 sqm gross area inclusive of not less than 3 Operation Theatres and Intensive Care or Neonatal Intensive Care within the last 5 years as primegeneral contractor,

- 2) New construction of a multi-floor building for such a healthcare project not less than 20,000 sqm gross area within max. 36 months as primegeneral contractor.
- 3) The Bidder has to provide proof that he has enough manpower available to work in parallel in several floors, roofs and façade with the target to finish the requested scope of work within the requested time frame of 390 days,
- 4) not less than 3 healthcare projects with more than 10,000 sqm gross area within the last 10 years as prime-general contractor,
- 5) not less than 2 renovation / retrofitting multi-floors healthcare or educational projects with not less than 20,000 sqm gross area within the last 10 years as sub-, prime or general contractor.

Pertanyaan :

- a. Total Nilai dari Kriteria yang dijelaskan pada klausul 4.2 (b) Construction Experience in key Activites yaitu 30 Points. Apakah bisa dijabarkan dari 30 Point tersebut point satu persatu dari tiap kriterianya?
- b. Dari Kriteria Nomor 5, apakah boleh melampirkan bangunan pendidikan selain Rumah Sakit Pendidikan ? Mohon Penjelasan.
- c. Apabila kita tidak memenuhi salah satu point pada klausul 4.2 (b) Construction Experience in key Activites apakah menggugurkan ? Atau hanya berpengaruh pada nilai score.

On Section III. Qualification and Evaluation Criteria Part 4. Construction Experience, a minimum of 80 out 100 points has to be reached Subpoints 4.2 (b) Construction Experience in Key Activities. Explained That:

For the above or any other contracts completed and under implementation as prime contractor, joint venture member, management contractor or subcontractor on or after the first day of the calendar year during the period stipulated in 4.2(a) above, a minimum construction experience in the following key activities successfully completed :

- 1) healthcare building, level general or teaching (University Hospital), minimum project volume 20,000 sqm gross area inclusive of not less than 3 Operation Theatres and Intensive Care or Neonatal Intensive Care within the last 5 years as primegeneral contractor,
- 2) New construction of a multi-floor building for such a healthcare project not less than 20,000 sqm gross area within max. 36 months as primegeneral contractor.
- 3) The Bidder has to provide proof that he has enough manpower available to work in parallel in several floors, roofs and façade with the target to finish the requested scope of work within the requested time frame of 390 days,
- 4) not less than 3 healthcare projects with more than 10,000 sqm gross area within the last 10 years as prime-general contractor,

5) not less than 2 renovation / retrofitting multi-floors healthcare or educational projects with not less than 20,000 sqm gross area within the last 10 years as sub-, prime or general contractor.

Questions :

- a. The Total Score (Points) of the Criteria described in clause 4.2 (b) Construction Experience in key Activites is 30 Points. Can it be explained from the 30 points one by one points from each criterion?
- b. From Criteria Number 5, is it permissible to attach an educational building other than the Teaching Hospital? Please explain.
- c. If we do not meet one of the points in clause 4.2 (b) Does Construction Experience in key Activites abort? Or it only affects the score.

Answer:

- a. all 5 criteria are rated equally. In this case the fulfillment of each of the 5 criteria will be granted 5 points
- b. the request for item 5 is clearly defined: not less than 2 renovation / retrofitting multi-floors healthcare or educational projects with not less than 20,000 sqm gross area within the last 10 years as sub-, prime or general contractor
- c. it will effect the score only

11. Pada Section III. Qualification and Evaluation Criteria Bagian 3.6 Personnel, Disyaratkan Experience in similar Work (Years) of Personel. Untuk memenuhi persyaratan Experience in Similar Work apakah bisa dipenuhi dengan melampirkan pengalaman Rumah Sakit?

In Section III. Qualification and Evaluation Criteria Part 3.6 Personnel, required Experience in similar Work (Years) of Personel. To fulfill the requirements of Experience in Similar Work can it be fulfilled by attaching Hospital experience?

Answer:

Can it be fulfilled by attaching Hospital experience as long as the level of experience is being documented.

Question from the Bidder dated April 14th, 2020

1. There is 2 Cost should be provided by the bidder, the General BoQ item and ESHS cost Schedule, my question is total our bidding in letter of bid provide those 2 price or just the General BoQ item?

Answer:

You quote ONE bid price only including the ESHS Cost Schedule, whereas the ESHS Cost Schedule shall be inserted into the BoQ under the Bill „General Items“

2. Are Bid Security should provide in Bidding Document or Separately?

Answer:

Please insert the original Bid Security into the envelope containing the Qualification documents.

3. In ESHS form, there is some criteria of ESHS level, I need to know the explanation the different ESHS level 1, ESHS level 2, and ESHS Level 3?

Answer:

Level ❶ basic = relevant to contracts with basic ESHS requirements

Typically for contracts in Projects with minor environmental and social construction related impacts and risks which do not require an Environmental and Social Impact Assessment (ESIA) and an Environmental and Social Monitoring Plan (ESMP) (Category “C”). During the implementation of the works only limited occupational health and safety measures are required, e. g.: minor works and small scale rehabilitation measures; few workers; low transport requirements; no worker camps required; no hazardous wastes; no working at heights or confined spaces; no heavy construction machinery; no external environmental risks like floodings; etc.

Level ❷ elevated = relevant to contracts with elevated ESHS requirements in addition to ❶.

Typically for contracts in Projects with limited environmental and social impacts and risks which require a standard ESIA (Category “B”). During the implementation of the works standard occupational health and safety measures are required, e. g.: less than 100 workers; less complex work site(s); transport of hazardous material; general OHS risks (welding, hazardous material) etc.

Level ❸ high = relevant to contracts with high ESHS requirements in addition to ❷

Typically for contracts in Projects with significant or long term environmental and social impacts and risks which require a separate comprehensive ESIA and an ESMP (Category “B+ and A”). During the implementation of the works particular occupational health and safety measures are required, e. g.: more than 100 workers; worker camp(s) required; significant risks at complex work sites(s); increased heavy load traffic; etc.

4. Just to make sure if we are right, the Key personnel data provided in Bid Document?

Answer:

Yes, data for key personnel shall be provided with the bid documents

5. Based on our country condition, Indonesia President has been announcing as a Nasional Disaster and based on WHO as a Pandemic situation, our movement to give the document directly to UNHAS, Makassar from Jakarta probably not too effective which is we implemented physical distancing nowadays, there is no addendum for this situation? such as a change to softcopy document first before the hardcopy delivered to PIU RS UNHAS

Answer:

Based on our announcement dated April 15th, 2020 about Prolongation of Bid Submission Date, sealed Qualification Documents and Bids must be delivered to the address indicated in the clause ITB 22.1 of the bidding document on or before May 11th, 2020 at 10:00 am CIT.

Question from the Bidder dated April 14th, 2020

1. Mohon Penjelasan Mengenai apa yang Dimaksud Dengan ESHS Level 1,2 dan 3. Dimanakah pebedaannya, bagaimana karakteristik yang dimaksud ESHS Level 1, Level 2 and Level 3

Please explain what is ESHS Levels 1.2 and 3. Where are the differences, what are the characteristics referred to as ESHS Level 1, Level 2 and Level 3?

Answer:

Level ❶ basic = relevant to contracts with basic ESHS requirements

Typically for contracts in Projects with minor environmental and social construction related impacts and risks which do not require an Environmental and Social Impact Assessment (ESIA) and an Environmental and Social

Monitoring Plan (ESMP) (Category “C”). During the implementation of the works only limited occupational health and safety measures are required, e. g.: minor works and small scale rehabilitation measures; few workers; low transport requirements; no worker camps required; no hazardous wastes; no working at heights or confined spaces; no heavy construction machinery; no external environmental risks like floodings; etc.

Level ② elevated = relevant to contracts with elevated ESHS requirements in addition to ①.

Typically for contracts in Projects with limited environmental and social impacts and risks which require a standard ESIA (Category “B”). During the implementation of the works standard occupational health and safety measures are required, e. g.: less than 100 workers; less complex work site(s); transport of hazardous material; general OHS risks (welding, hazardous material) etc.

Level ③ high = relevant to contracts with high ESHS requirements in addition to ②

Typically for contracts in Projects with significant or long term environmental and social impacts and risks which require a separate comprehensive ESIA and an ESMP (Category “B+ and A”). During the implementation of the works particular occupational health and safety measures are required, e. g.: more than 100 workers; worker camp(s) required; significant risks at complex work sites(s); increased heavy load traffic; etc.

2. Apakah EXP - 5.2 Perlu dilampirkan pada pevelangan ini? Dikarenakan pada Contoh Form EXP- 5.2 pada Section IV. Qualification and Bidding Forms terdapat klausul "Not applicable as the construction works for the rehabilitation of UNHAS Building BCD is being rated ESHS level 2. Mohon Penjelasan.

Does Form EXP-5.2 need to be attached to Bid Documents? Because in Form EXP-5.2 on Section IV. Qualification and Bidding Forms there is a clause : "Not applicable as the construction works for the rehabilitation of UNHAS Building BCD is being rated ESHS level 2". Please Explain.

Answer:

Please attach Form EXP-5.2 to the Qualification Documents (not to the Bid documents!) that the evaluators can see your ESHS experience level. In any case there will be full points allocated due to the rating of Level 2, even form EXP-5.2 is not being attached or there is no experience with projects of significant ESHS impact.

3. Jika Perusahaan Kami tidak Ber- JV apakah Form ELI-1.2 (b) Declaration of Association tetap harus diisi? Mohon Penjelasan

If our company does not on JV, does the Form ELI-1.2 (b) Declaration of Association still need to be filled out? Please explain

Answer:

If you do not form a JV in any form, of course you do not need to attach a Declaration of Association.

4. Mohon Penjelasan tata cara penyampulan dokumen penawaran? Apakah benar bahwa :
- Sampul 1 : Dokumen Kualifikasi
Sampul 2 : Dokumen Penawaran Teknis dan Harga. Apabila iya, Maka Jaminan Penawaran asli apakah Masuk Kedalam Sampul 2 atau Dalam Sampul terpisah.

Please explain the procedure for the submission of bid documents? Is it true that:

Envelope 1: Qualification Document

Envelope 2: Technical Bidding and Pricing Documents.

If yes, then the original Bid Guarantee is attached into Envelope 2 or in a separate Envelope. Please Explain.

Answer:

Yes, this is true, Envelope 1 shall contain the Qualification Documents, Envelope 2 the Bid and Pricing documents. Place the Bid Security original into envelope 1 together with the Qualification documents.

5. Mohon diberikan Spesifikasi Type Surgical Lamp dikarenakan dokumen yang kami terima belum tertera.
Please provide a Specification of Surgical Lamp because in the documents that we received have not yet been listed.

Answer:

In the BoQ there is no request for surgical lamps.

Question from the Bidder dated April 15th, 2020

1. Please Give us the Information about Section IX Particular Conditions Page 264 Sub- Clause 17.6 Maximum total liability of the Contractor to the Employer : The product of 1,1 times the Accepted Contract Amount ?

Answer:

Exactly, this will be the total MAXIMUM liability in case of default by the Contractor

2. Because there are differences in data between the documents and Q&A Tender, To make sure, whether the Information below is correct :
 - a. ICB No. : 505203 BMZ209918111-Construction Works-1
 - b. ICB No. and Title : 505203 BMZ209918111-Construction Works-1, UNHAS Hospital Development Project, Makassar, BMZ 2099 18 111
 - c. Number of Invitation For Bids : 505203 BMZ209918111-Construction Works-1
 - d. Name of Project : UNHAS Hospital Development Project, Makassar, BMZ 2099 18 111
 - e. Name of The Recipient of Bid Security & The Employer : Ministry of Ministry of Education and Culture of the Republic of Indonesia
 - f. Address of The Recipient of Bid Security & The Employer : PIU RS UNHAS Office Jl. Perintis Kemerdekaan km. 10, Cancer Center Building Makassar 90245 South Sulawesi, Republic of Indonesia.

Please explain

Answer:

- a. Correct.
 - b. The name of the ICB is: Construction Works for UNHAS building B,C,D.
 - c. There is no number of Invitation For Bids.
 - d. Correct.
 - e. Ministry of Education and Culture of the Republic of Indonesia
 - f. PIU KfW-UNHAS Office, Jl. Perintis Kemerdekaan km. 10, Cancer Center Building 1st floor, PIU Room, 90245 Makassar, South Sulawesi.
3. Does Form EXP-5.2 need to be filled (attach) to Bid Documents? Because in Form EXP-5.2 on Section IV. Qualification and Bidding Forms there is a clause: "Not applicable as the construction works for the rehabilitation of UNHAS Building BCD is being rated ESHS level 2"
Please Explain.

Answer:

Please attach Form EXP-5.2 to the Qualification Documents (not to the Bid documents!) that the evaluators can see your ESHS experience level. In any case there will be full points allocated due to the rating of Level 2, even form EXP-5.2 is not being attached or there is no experience with projects of significant ESHS impact.

4. If Form EXP-5.2 need to be filled/Attach Bid Documents? Please explain what kind of data should we attached and explain in that form. Can we attached Experience in Project with Significant ESHS Impact not in Hospital/University Projects.

Answer:

Yes, you can. It will be helpful to judge your overall level of experience.

5. On Section IV. Qualification and Bidding Forms, Does Form EQP-4.3 Specific Construction Equipment need to be filled (attach) to Bid Documents (Qualification Documents). If yes, is it filled with equipment that will be used in the construction of the project? Please explain.

Answer:

We do not anticipate the usage of any special equipment to fulfil the works. Thats why you do not need to submit the form EQP-4.3.

Question from the Bidder dated April 15th, 2020

1. Penilaian Construction Experience yang terdapat Pada Section III. Qualification and Evaluation Criteria Points 4. Construction Experience, a Minimum of 80 out of 100 points has to be reached Subpoints 4.2 (b) Construction Experience in Key Activities. Dijelaskan bahwa :
- For the above or any other contracts completed and under implementation as prime contractor, joint venture member, management contractor or subcontractor on or after the first day of the calendar year during the period stipulated in 4.2(a) above, a minimum construction experience in the following key activities successfully completed :
- 1) healthcare building, level general or teaching (University Hospital), minimum project volume 20,000 sqm gross area inclusive of not less than 3 Operation Theatres and Intensive Care or Neonatal Intensive Care within the last 5 years as primegeneral contractor,
 - 2) New construction of a multi-floor building for such a healthcare project not less than 20,000 sqm gross area within max. 36 months as primegeneral

contractor.

3) The Bidder has to provide proof that he has enough manpower available to work in parallel in several floors, roofs and façade with the target to finish the requested scope of work within the requested time frame of 390 days,

4) not less than 3 healthcare projects with more than 10,000 sqm gross area within the last 10 years as prime-general contractor,

5) not less than 2 renovation / retrofitting multi-floors healthcare or educational projects with not less than 20,000 sqm gross area within the last 10 years as sub-, prime or general contractor.

Pertanyaan :

- a. Total Nilai dari Kriteria yang dijelaskan pada klausul 4.2 (b) Construction Experience in key Activites yaitu 30 Points. Apakah bisa dijabarkan dari 30 Point tersebut point satu persatu dari tiap kriterianya?
- b. Dari Kriteria Nomor 5, apakah boleh melampirkan bangunan pendidikan selain Rumah Sakit Pendidikan ? Mohon Penjelasan.
- c. Apabila kita tidak memenuhi salah satu point pada klausul 4.2 (b) Construction Experience in key Activites apakah menggugurkan ? Atau hanya berpengaruh pada nilai score.

On Section III. Qualification and Evaluation Criteria Part 4. Construction Experience, a minimum of 80 out 100 points has to be reached Subpoints 4.2 (b) Construction Experience in Key Activities. Explained That: For the above or any other contracts completed and under implementation as prime contractor, joint venture member, management contractor or subcontractor on or after the first day of the calendar year during the period stipulated in 4.2(a) above, a minimum construction experience in the following key activities successfully completed :

1) healthcare building, level general or teaching (University Hospital), minimum project volume 20,000 sqm gross area inclusive of not less than 3 Operation Theatres and Intensive Care or Neonatal Intensive Care within the last 5 years as primegeneral contractor,

2) New construction of a multi-floor building for such a healthcare project not less than 20,000 sqm gross area within max. 36 months as primegeneral contractor.

3) The Bidder has to provide proof that he has enough manpower available to work in parallel in several floors, roofs and façade with the target to finish the requested scope of work within the requested time frame of 390 days, 4) not less than 3 healthcare projects with more than 10,000 sqm gross area within the last 10 years as prime-general contractor,

4) not less than 3 healthcare projects with more than 10,000 sqm gross area within the last 10 years as prime-general contractor,

5) not less than 2 renovation / retrofitting multi-floors healthcare or educational projects with not less than 20,000 sqm gross area within the last 10 years as sub-, prime or general contractor.

Questions :

- a. The Total Score (Points) of the Criteria described in clause 4.2 (b) Construction Experience in key Activites is 30 Points. Can it be explained from the 30 points one by one points from each criterion?
- b. From Criteria Number 5, is it permissible to attach an educational building other than the Teaching Hospital? Please explain.
- c. If we do not meet one of the points in clause 4.2 (b) Does Construction Experience in key Activites abort? Or it only affects the score.

Answer:

- a. all 5 criteria are rated equally. In this case the fulfillment of each of the 5 criteria will be granted 5 points.
 - b. the request for item 5 is clearly defined: not less than 2 renovation/retrofitting multi-floors healthcare or educational projects with not less than 20,000 sqm gross area within the last 10 years as sub-, prime or general contractor.
 - c. it will effect the score only.
2. Pada lelang paket pekerjaan ini apakah diperbolehkan melakukan Joint Operation (Join Venturer) dengan peserta yang tidak mengikuti acara aanwijzing? Dikarenakan pada Section II. QUalification and Bid Data Sheet Point A. Introduction Sub Points ITB 4.1 *Maximum number of members in the JV shall be not applicable*. Mohon Penjelasan.

At this Tender is it permissible to conduct Joint Operations (Joint Venturers) with Participants not participating in the Tender? Due to Section II. Qualification and Bid Data Sheet Point A. Introduction ITB Sub Points 4.1 Maximum number of members in the JV shall / 1 be not applicable. Please explain.

Answer:

ITB Sub Clause 4.1 just explains that the number of JV Partners is not limited. Any Bidder may form a joint venture with any number partners. Also partners not participating in this Tender are permissable as long as they are formally members of the JV formed by the Bidder

3. Berdasarkan Surat Edaran Nomor: SE-4/MBU/04/2020 Tanggal 06 April 2020 tentang Larangan Kegiatan Berpergian ke Luar Daerah dan/atau Kegiatan Mudik dalam Upaya Pencegahan Penyebaran Corona Virus Disease 2019 (Covid-19) dan Peraturan Pemerintah Republik Indonesia Nomor: 21 Tahun 2020, Tanggal 31 Maret 2020 tentang Pedoman Pembatasan Sosial Berskala Besar dalam Rangka Percepatan Penanganan Corona Virus Disease 2019 (Covid-19) serta Peraturan Menteri Kesehatan Republik Indonesia tentang Pedoman Pembatasan Sosial Berskala Besar dalam Rangka Percepatan Penanganan Corona Virus Disease 2019 (Covid-19) mohon untuk dapat

diperpanjang batas akhir waktu pemasukan penawaran yang semula tanggal 20 April 2020 pukul 10.00 WITA menjadi sampai dengan tanggal 10 Mei 2020.

Based on Circular Number: SE-4/MBU/04/2020 dated April 6, 2020 Regarding the Prohibition of Traveling Activities Outside the Region and/or Mudik Activities in Preventing the Spread of Corona Virus Disease 2019 (COVID-19) and Government Regulation of the Republic of Indonesia Number: 21 of 2020, Date 31 March 2020 concerning Guidelines for Large-Scale Social Restrictions in The Framework for Accelerating the Management of Corona Virus Disease 2019 (COVID-19) as well as the Regulation of the Minister of Health of the Republic of Indonesia concerning Guidelines for Large-Scale Social Restrictions in the Framework of Accelerating the Management of Corona Virus Disease 2019 (COVID-19) April 2020 o'clock. 10:00 WITA to be until 10 May 2020.

Answer:

Based on our announcement dated April 15th, 2020 about Prolongation of Bid Submission Date, The Bid Submission date has been officially extended until May 11th, 2020 at 10:00 CIT.

Question from the Bidder dated April 21st, 2020

1. Pada BoQ Section 12.4 & 12.5 baris 289 dan 419 ada item surgical lamp mohon dapat diberikan spesifikasinya

In BoQ Sections 12.4 & 12.5 lines 289 and 419 (attached) there are surgical lamp items, please provide specifications.

Answer:

Please ignore the surgical lamp item both for “supply only” and “install only” in BoQ 12.4 & 12.5 lines 289 and 419. This information was given for information only that such a lamp shall be supplied at a later stage.

Question from the Bidder dated April 27th, 2020

1. Tata cara pemasukan dokumen penawaran mengingat pada kondisi saat ini tidak memungkinkan mengirim dokumen penawaran secara langsung?

The process of Bid Documents Submission considering that current condition is not possible to send bid documents directly (Hardcopy)?

2. Apakah boleh mengirimkan dokumen penawaran dalam bentuk softcopy saja melalui email, dropbox, google drive/LPSE atau melalui media lainnya?

Is it permissible to send softcopy of Bid documents via Email, Dropbox, Google Drive/LPSE or through other media?

3. Apakah batas akhir pemasukan dokumen penawaran dapat diperpanjang sampai dengan tanggal 02 Juni 2020 atau setelah berakhirnya masa berlaku larangan penggunaan sarana transportasi (peraturan dari Kementerian Perhubungan Republik Indonesia).

Could the deadline for submission of bid documents be extended until June 2nd, 2020 or after the expiry of The Temporary Prohibition of the use of transportation Facilities (Regulation of The Minister of Transportation of the Republic of Indonesia)

Answer to question number 1-3:

With regard to the online submission, PIU is now waiting for No Objection and procedure from KfW. The PIU will soon announce it as soon as the no objection letter is officially issued. However, in the case of the No Objection Letter has not been issued until the deadline of the bidding submission, the current mode is applied accordingly.

Question from the Bidder dated April 28th, 2020

A. Permohonan Pemasukan Online atau Pengunduran Waktu (Request for Online Submission or Postpone Submission Date)

1. Mencermati situasi sampai dengan saat ini mengenai Wabah Covid 19 yang semakin meluas serta telah diberlakukannya Peraturan Menteri Perhubungan No. PM 25 Tahun 2020 Tentang Pengendalian Transportasi Selama Masa Mudik Idul Fitri Tahun 1441 H Dalam Rangka Pencegahan Penyebaran Corona Virus Disease 2019 (COVID-19) yang memberlakukan Larangan Sementara Transportasi Darat, Transportasi Perkeretaapian, Transportasi Laut dan Transportasi Udara mulai Tanggal 24 April 2020 sampai dengan 31 Mei 2020 sehingga hal tersebut sangat menyulitkan kami dalam penyampaian dokumen ke lokasi pemasukan di Makassar. Sehubungan dengan hal tersebut diatas mohon penyampaian dokumen penawaran pada tanggal 11 Mei 2020 dapat dilakukan melalui Online / Upload dan jika penyampaian melalui Online / Upload tidak dimungkinkan mohon pemasukan dokumen Hardcopy dapat dimundurkan menjadi tanggal 05 Juni 2020 setelah Transporasi Udara dibuka kembali.

Observing the current situation regarding the 19th Covid outbreak which is increasingly widespread and the enactment of the Minister of Transportation Regulation No. PM 25 of 2020 concerning Transportation Control during Idul Fitri's Homecoming Year 1441 H in the Context of Preventing the Spread of Corona Virus Disease 2019 (COVID-19) which imposes Temporary Prohibitions on Land Transportation, Railway Transportation, Sea Transportation and Air Transportation from 24 April 2020 to May 31, 2020 so that it was very difficult for us to deliver documents to the import location in Makassar. Regarding that issue, please the submission of the bid documents on May 11, 2020, can be done via Online / Upload and if submission via Online / Upload is not possible, please submission of Hardcopy documents can be postponed to June 5, 2020 after Air Transport is reopened.

Answer:

With regard to the online submission, PIU is now waiting for No Objection and procedure from KfW. The PIU will soon announce it as soon as the no objection letter is officially issued. However, in the case of the No Objection Letter has not been issued until the deadline of the bidding submission, the current mode is applied accordingly.

B. Daftar Pertanyaan Teknis (List of Technical Question)

1. Pada Ruang OT (diwarnai kuning) dinding diantara ruang OT apakah dinding HPL 19 cm single atau double dinding?

In the OT Room (colored yellow) the wall between the OT room is the wall HPL 19 cm single or double wall?

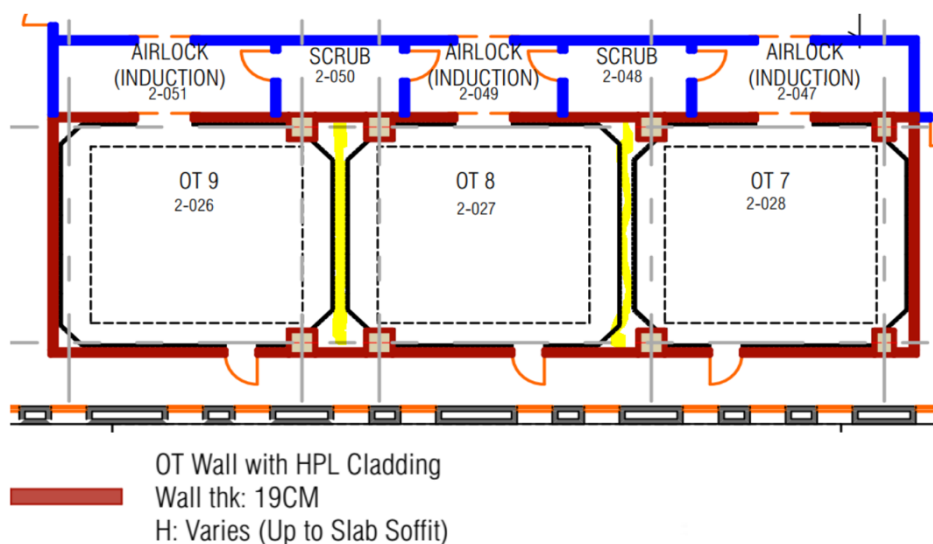

Answer:

Please refer to the 19cm wall type as shown on Drawing A.11.35 Type 7, see also Drawing A.6.2 reflecting the HPL Cladding location.

2. Pada File UNHAS_A.9.6_Unbuilt Door Sched A_IV_2020_01_23.xls Kolom Door Protection Door menyebutkan Type DP-A, DP-B dan DP-C mohon diberikan referensi gambarnya dan menggunakan material apa ?

In the UNHAS_A.9.6_Unbuilt Door Sched File A_IV_2020_01_23.xls Column Door Protection Door mentions Type DP-A, DP-B and DP-C please given the reference picture and using what material?

Width, clear structure, un	Height, clear structure, un	Door Open	Door Type	Door Protection Ty	Fanlight/Transom window (above door)	Vis
2500 mm	2800 mm	Swing	D	-	Fanlight/Transom window	
900 mm	2800 mm	Swing	D	DP-B	Fanlight/Transom window	Vi
900 mm	2800 mm	Swing	D	DP-C	Fanlight/Transom window	Vi
900 mm	2800 mm	Swing	D	DP-C	Fanlight/Transom window	Vi
900 mm	2800 mm	Swing	D	DP-C	Fanlight/Transom window	Vi
900 mm	2800 mm	Swing	E	DP-B	Fanlight/Transom window	
1100 mm	2100 mm	Swing	J	DP-B	-	
900 mm	2800 mm	Swing	F	DP-B	Fanlight/Transom window	

Answer:

The reference drawing for the Door Protection is found in the A.9.7. see screenshot below:

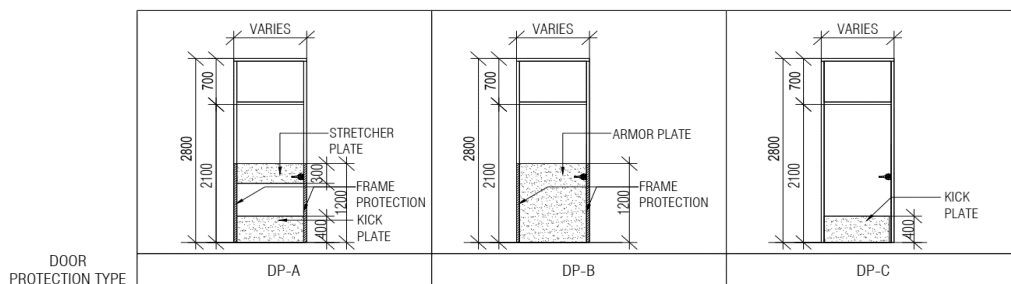

The material is Door Plates Protection - .040" (1.02mm) and .060" (1.52mm) thick Acrovyn or 16 gauge Stainless steel or similar.

Door edge protectors or frame protection are available in two styles, a "U" shape and an "L" shape. also in Acrovyn sheet in .040" (1.02mm) or .060" (1.52mm) thickness or 16 gauge Stainless steel or similar.

3. Mohon Penjelasan untuk Pintu ruang OT apakah dipastikan menggunakan Kayu (Timber) ? Hardware yang digunakan apakah menggunakan standar pintu Hermatic Door ?

Please explain for the OT room door whether to use Timber (Timber)? The hardware used is the standard door Hermatic Door?

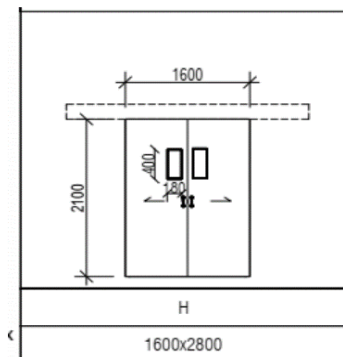

Answer:

Timber is OK to be used but the door must be with HPL cladding. The door must be a hermetic door.

4. Mohon konfirmasinya pintu BQ didalam keterangan engineering door fire rated 60 minutes tetapi menggunakan panic bar, di dalam table door schedule pintu untuk lokasi OPD ukuran 1.100 mm wide x 2.100 mm height adalah pintu besi.

Please confirm the BQ door in the door fire rated engineering statement 60 minutes but using a panic bar, in the door schedule door table for OPD locations the size of 1,100 mm wide x 2,100 mm height is an Steel door.

Ref No.	SECTION 08.2 - INTERNAL DOORS AND WINDOWS	Qty	Unit	Rate \$, USD	Amount \$, USD
08.2	INTERNAL DOORS AND FRAMES (Cont'd)				
	Supply, assemble, set and install 60minutes fire rated engineering doors with panic bar and door closer , consists of solid engineering timber frames; covered with plastic laminate finish, door leaves covered plastic laminate finish; supply and fixing ironmongery complete with all fixing accessories including U-shaped motorized door edge protection , pointing frames in mastic sealant, easing operable parts, protecting frames and cleaning on completion, all as described (Dwg. No.A.9.6 & A.9.7)				
	1st Floor (Dwg. No. A.9.1)				
A	Single leaf door units; overall size 1.100mm wide x 2.100 mm high; door protection DP-B size 1.100mm wide x 1.200mm high; to Out Patient Department (OPD)	2	No.		
	2nd Floor (Dwg. No. A.9.2)				
B	Ditto; ditto; ditto; to CSSD	1	No.		

Answer:

Yes confirmed the material is Steel Door to achieve the 60 minutes fire rated requirement for the Fire exit doors which is already reflected in the Unbuilt Door Schedule A.9.6.

5. Mohon diberikan spesifikasi Atap Metal pada pekerjaan slanted roof, menggunakan ketebalan berapa ?

Please provide Metal Roof specifications on slanted roof work, using what thickness?

Answer:

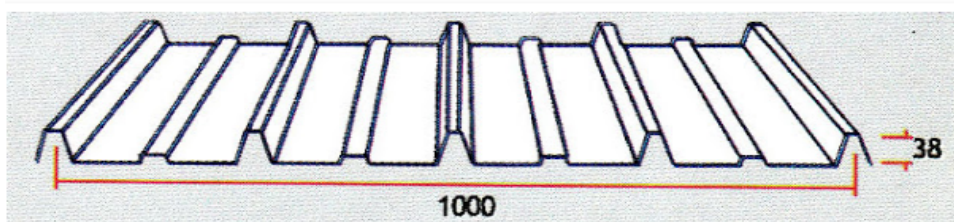

The thickness of the slanted roof depends on the offered system by the bidder. This means that every system has different thicknesses to ensure the stability of the individual panels used. As an orientation only, we would like to give the following indicative dimensions only:

Rib type Roof long span.

Guage 26 (0.404 millimeters thick)

Width: 1000 mm

Wave: 5 waves

Basic material: Hi-Ten Steel G550, Soft steel G300

Material Souces:

Zincalume

Eternal

Saranalume

Alu Zinc (Aluminum Zinc Alloy Coated)

Please refer to the drawings pdf "UNHAS_A.20.1_Slanted Roof_RF_VWXY_RI_2020_01_13 and;

UNHAS_A.20.3_Slanted Roof_5F_Z 1_RI_2020_01_13".

6. Mohon diberikan spesifikasi insulasi atap menggunakan ketebalan lapisan material apa saja dan ketebalannya?

Please provide roof insulation specifications using layer thickness any material and thickness?

Answer:

Roof insulation is 15mm thick layer EPE foam Roof heat insulation (Double sided lamination with aluminum film) over a galvanize welding netting support (75mm x 75mm square opening)

Galvanize Roof Mesh 3315 or BRC 3315 Mesh or approved equivalent (Thickness x hole size x Width x length)

Type 3315: 1.4mm x 75 mm x 1.8 m x 30 m.

Roof Insulation Specs:

PROPERTIES	PAPAMETER
Description	Regular Size: 1.2m width x 40m length
	2.4m width x 40m length
	Thickness:3-26mm
	Length and width can be customized
Foam Colour	Blue ,Green ,Black ,White etc
Density of Foam	25-27kg/m ³
R-Vaule	0.1-0.75 m ² K/W
Thermal Conductivity(ASTM C518)	0.041 W/m ² K
Reflectivity	96%-97%
Emissivity	0.04
Edge Tearing Resistance (AS/NZS 4201.2)	432N
Material Structure	AL+EPE Foam
	AL+EPE Foam+AL
	AL woven+EPE Foam +AL
	Coating AL+EPE Foam +AL
	Reinforced AL+EPE Foam+Reinforced Al
	● EPE Foam Can be fire retardant
	● Aluminum foil can be colour coating or anti-glare coating
	● Aluminum foil can be reinforced fiberglass or woven fabric